

Pipe



Designers Guide

Pipe Type, Size & Schedule Selection

- 1) Determine if pipe is carbon or stainless steel.
- 2) Establish the flow rate through the pipe in US Gal/min.
- 3) Select the desired line velocity in FPS (ft./sec.)

Recommended Oil Velocities

TABLE 1.

Suction Lines	Return Lines	Pressure Lines						
		0-150psi	150-375psi	375-750psi	750-1500psi	1500-2250psi	2250-3000psi	3000-5000psi
≤5FPS	≤10FPS	≤10FPS	≤12FPS	≤13FPS	≤14FPS	≤16FPS	≤18FPS	≤20FPS

- 4) Establish system design pressure (PSI)
- 5) Go to Table 2.
Under the selected line velocity column read down until the approximate flow rate is found. Read across to the left column showing the nominal pipe size and schedule required.
- 6) Go to Table 5 for carbon steel. (Table 6 for stainless steel)
Under the nominal pipe size selected above, read down the column showing available pipe and corresponding pressure rating to meet the design criteria.
The reference section shown on the right hand column of Table 5 will give more detailed information on the selected pipe connection style.

Example:

System delivering 250 GPM at 3500 PSI with a design velocity of around 20 FPS using carbon steel pipe.

Selection:

TMP52CD pipe, flared, schedule 80, 2 1/2" size would meet the design requirement of this example.



TMI® Pipe Flow/Velocity Guide

see page A5 for connection pressure rating

TABLE 2.

Nominal Pipe Size		Internal Area	Bore Dia. (in)	Line Velocity						
				GPM@ 2FPS	GPM@ 5FPS	GPM@ 10FPS	GPM@ 15FPS	GPM@ 20FPS	GPM@ 25FPS	GPM@ 30FPS
1/2"	Sch40	0.304	0.622	1.9	4.7	9.5	14.2	18.9	23.7	28.4
	Sch80	0.234	0.546	1.5	3.6	7.3	10.9	14.6	18.2	21.9
3/4"	Sch40	0.533	0.824	3.3	8.3	16.6	24.9	33.2	41.6	49.9
	Sch80	0.432	0.742	2.7	6.7	13.5	20.2	27.0	33.7	40.4
1"	Sch40	0.864	1.049	5.4	13.5	26.9	40.4	53.9	67.3	80.8
	Sch80	0.719	0.957	4.5	11.2	22.4	33.6	44.8	56.0	67.3
1 1/4"	Sch40	1.496	1.380	9.3	23.3	46.6	69.9	93.2	116.5	139.9
	Sch80	1.283	1.278	8.0	20.0	40.0	60.0	80.0	100.0	119.9
1 1/2"	Sch40	2.036	1.610	12.7	31.7	63.5	95.2	126.9	158.6	190.4
	Sch80	1.767	1.500	11.0	27.5	55.1	82.6	110.2	137.7	165.2
	Sch160	1.406	1.338	8.8	21.9	43.8	65.7	87.7	109.6	131.5
	Heavy Wall	1.852	1.540	11.5	28.9	57.7	86.6	115.4	144.3	173.1
2"	Sch40	3.356	2.067	20.9	52.3	104.6	156.9	209.2	261.5	313.8
	Sch80	2.953	1.939	18.4	46.0	92.0	138.1	184.1	230.1	276.1
	Sch160	2.235	1.687	13.9	34.8	69.7	104.5	139.4	174.2	209.0
	Heavy Wall	2.923	1.930	18.2	45.6	91.1	136.7	182.2	227.8	273.3
2 1/2"	Sch40	4.788	2.469	29.8	74.6	149.2	223.8	298.5	373.1	447.7
	Sch80	4.238	2.323	26.4	66.1	132.1	198.2	264.2	330.3	396.3
	Sch160	3.547	2.125	22.1	55.3	110.6	165.8	221.1	276.4	331.7
	Heavy Wall	4.383	2.360	27.3	68.3	136.6	204.9	273.2	341.5	409.8
3"	Sch40	7.393	3.068	46.1	115.2	230.4	345.6	460.8	576.1	691.3
	Sch80	6.605	2.900	41.2	102.9	205.9	308.8	411.8	514.7	617.6
	Heavy Wall	6.487	2.870	40.4	101.1	202.2	303.3	404.4	505.5	606.6
4"	Sch40	12.730	4.026	79.4	198.4	396.8	595.2	793.6	992.0	1190.4
	Sch80	11.500	3.826	71.7	179.2	358.4	537.6	716.8	896.0	1075.4
	SchXXS	7.803	3.152	48.6	121.6	243.2	364.9	486.5	608.1	729.8
	Heavy Wall	8.795	3.350	54.8	137.1	274.1	411.2	548.3	685.4	822.4
5"	Sch40	20.006	5.047	124.7	311.8	623.6	935.3	1247.1	1558.9	1870.7
	SchXXS	14.610	4.063	91.1	227.7	455.4	683.1	910.8	1138.4	1366.1
6"	Sch40	28.890	6.065	180.1	450.2	900.5	1350.7	1801.1	2251.2	2701.4
	SchXXS	21.147	4.897	131.8	329.6	659.1	988.7	1318.3	1647.9	1977.4
8"	Sch40	50.027	7.981	311.9	779.6	1559.3	2338.9	3118.6	3898.2	4677.8
	Sch160	36.456	6.813	227.3	568.1	1136.3	1704.4	2272.6	2840.7	3408.9

• FLOW IS IN US GALLONS/MIN.



TMI® Pipe - Pressure Rating Guide

Size Range & Maximum Allowable Working Pressure - ^{PSI} Bore dia.(in)

Carbon Steel (Table 3.)

Pipe	Nominal Pipe Size*												Ref. Page
	1/2"	3/4"	1"	1 1/4"	1 1/2"	2"	2 1/2"	3"	4"	5"	6"	8"	
TMP52CD SCHEDULE 40 PIPE	6200 0.622	5000 0.824	4700 1.049	3900 1.380	3500 1.610	2900 2.067	-	-	-	-	-	-	A6
TMP44HR SCHEDULE 40 PIPE	-	-	-	-	-	-	2600 2.469	2300 3.068	1900 4.026	1700 5.047	1500 6.065	1300 7.981	A7
TMP52CD SCHEDULE 80 PIPE	8600 0.546	7000 0.742	6500 0.957	5400 1.278	4900 1.500	4200 1.939	4500 2.323	3900 2.900	3420 3.826	-	-	-	A6
TMP52CD SCHEDULE 160 PIPE	-	-	-	-	6930 1.338	6750 1.689	6030 2.125	-	-	-	-	-	A6
TMP52CD HEAVY WALL PIPE	-	-	-	-	7400 1.540	6100 1.930	5900 2.360	5900 2.870	6200 3.350	-	-	-	A6
TMP106HR HEAVY WALL PIPE	-	-	-	-	-	-	-	-	-	5200 4.063	5000 4.897	4100 6.813	A7

* FOR SIZES 10" OR LARGER CONSULT FACTORY

- NOTE:
- 1) MAXIMUM ALLOWABLE WORKING PRESSURES ARE BASED ON THE PIPE RATING PER ANSI B31.3
 - 2) TYPE 52CD MATERIAL ALLOWABLE STRESS - 24,000 PSI PER ANSI B31.3
 - 3) TYPE 44HR MATERIAL ALLOWABLE STRESS - 20,000 PSI PER ANSI B31.3
 - 4) TYPE 46CD MATERIAL ALLOWABLE STRESS - 34,000 PSI PER ANSI B31.3
 - 5) TYPE 106HR MATERIAL ALLOWABLE STRESS - 20,000 PSI PER ANSI B31.3

Stainless Steel (Table 4.)

Pipe	Nominal Pipe Size*												Ref. Page
	1/2"	3/4"	1"	1 1/4"	1 1/2"	2"	2 1/2"	3"	4"	5"	6"	8"	
TMP304/316SS SCHEDULE 40 PIPE	5000 0.622	4100 0.824	3800 1.049	3100 1.380	2800 1.610	2400 2.067	2600 2.469	2300 3.068	1900 4.026	1700 5.047	1500 6.065	1300 7.981	A8
TMP304/316SS SCHEDULE 80 PIPE	7000 0.546	5700 0.742	5300 0.957	4400 1.278	4000 1.500	3400 1.939	3600 2.323	3200 2.900	-	-	-	-	A8
TMP2205SS SCHEDULE 80 PIPE	-	-	-	6600 1.278	6000 1.500	5200 1.939	-	-	-	-	-	-	A9
TMP304/316SS HEAVY WALL PIPE	-	-	-	-	-	-	-	*	5800 3.152	5200 4.063	5000 4.897	4000 6.813	A9

* FOR 3" SIZE AND SIZES 10" OR LARGER CONSULT FACTORY

- NOTE:
- 1) MAXIMUM ALLOWABLE WORKING PRESSURES ARE BASED ON THE PIPE RATING PER ANSI B31.3
 - 2) TYPE 304/316SS MATERIAL ALLOWABLE STRESS - 20,000 PSI PER ANSI B31.3
 - 2) TYPE 2205SS MATERIAL ALLOWABLE STRESS - 30,000 PSI PER ANSI B31.3



TMI® Pipe Connection - Pressure Rating Guide

Size Range & Maximum Allowable Connection Working Pressure - ^{PSI}
Bore dia.(in)

Carbon Steel (Table 5.)

Connection Style	Pipe End Style	Pipe	Nominal Pipe Size*												Ref. Section
			1/2"	3/4"	1"	1 1/4"	1 1/2"	2"	2 1/2"	3"	4"	5"	6"	8"	
CARBON STEEL FLANGE	FLARED	TMP52CD SCHEDULE 40 PIPE	6000 0.622	5000 0.824	4700 1.049	3900 1.380	3500 1.610	2900 2.067	-	-	-	-	-	-	B
		TMP44HR SCHEDULE 40 PIPE	-	-	-	-	-	-	2600 2.469	2300 3.068	-	-	-	-	B
		TMP52CD SCHEDULE 80 PIPE	6000 0.546	6000 0.742	6000 0.957	5400 1.278	4900 1.500	4200 1.939	4500 2.323	3900 2.900	3420 3.826	-	-	-	B
	TMP52CD SCHEDULE 160 PIPE	-	-	-	-	6930 1.338	6750 1.689	6030 2.125	-	-	-	-	-	B	
	RETAIN RING	TMP52CD HEAVY WALL PIPE	-	-	-	-	6000 1.540	6000 1.930	5800 2.360	5800 2.870	5800 3.350	-	-	-	C
		TMP106HR HEAVY WALL PIPE	-	-	-	-	-	-	-	-	-	4000 4.063	3700 4.897	3500 6.813	C
TMP44HR SCHEDULE 40 PIPE		-	-	-	-	-	-	750 2.469	750 3.068	750 4.026	750 5.047	700 6.065	600 7.981	D	
DUCTILE IRON COUPLING	ROLL/CUT GROOVED	TMP44HR SCHEDULE 40 PIPE	-	-	-	-	-	750 2.469	750 3.068	750 4.026	750 5.047	700 6.065	600 7.981	E	

* FOR SIZES 10" OR LARGER CONSULT FACTORY

- NOTES: 1) THE FLARED PIPE SYSTEM IS MORE COST EFFECTIVE THAN THE RETAIN RING SYSTEM.
2) ROLL GROOVED SCHEDULE 40 PIPE IS MOST COMMONLY USED FOR UNRESTRICTED LOW PRESSURE HYDRAULIC RETURN LINES AND LOW PRESSURE LUBRICATION LINES.
3) MAXIMUM ALLOWABLE WORKING PRESSURES ARE BASED ON THE LOWER OF THE PIPE RATING PER ANSI B31.3 OR THE CARBON STEEL/DUCTILE IRON CONNECTION RATING..

Stainless Steel (Table 6.)

Connection Style	Pipe End Style	Pipe	Nominal Pipe Size*												Ref. Section
			1/2"	3/4"	1"	1 1/4"	1 1/2"	2"	2 1/2"	3"	4"	5"	6"	8"	
CARBON STEEL FLANGE	FLARED	TMP304/316SS SCHEDULE 40 PIPE	5000 0.622	4000 0.824	3800 1.049	3100 1.380	2800 1.610	2400 2.067	2500 2.469	2000 3.068	-	-	-	-	B
		TMP304/316SS SCHEDULE 80 PIPE	6000 0.546	5700 0.742	5300 0.957	4400 1.278	4000 1.500	3400 1.939	3600 2.323	3200 2.900	-	-	-	-	B
		TMP2205SS SCHEDULE 80 PIPE	-	-	-	6000 1.278	6000 1.500	5200 1.939	-	-	-	-	-	-	B
	RETAIN RING	TMP304/316SS HEAVY WALL PIPE	-	-	-	-	-	-	-	*	5800 3.152	4000 4.063	3700 4.897	3500 6.813	C
		TMP304/316SS SCHEDULE 40 PIPE	-	-	-	-	-	-	750 2.469	750 3.068	750 4.026	750 5.047	700 6.065	600 7.981	D
DUCTILE IRON COUPLING	ROLL/CUT GROOVED	TMP304/316SS SCHEDULE 40 PIPE	-	-	-	-	-	750 2.469	750 3.068	750 4.026	750 5.047	700 6.065	600 7.981	E	

* FOR 3" SIZE AND SIZES 10" OR LARGER CONSULT FACTORY

- NOTES: 1) THE FLARED PIPE SYSTEM IS MORE COST EFFECTIVE THAN THE RETAIN RING SYSTEM.
2) ROLL GROOVED SCHEDULE 40 PIPE IS MOST COMMONLY USED FOR UNRESTRICTED LOW PRESSURE HYDRAULIC RETURN LINES AND LOW PRESSURE LUBRICATION LINES.
3) MAXIMUM ALLOWABLE WORKING PRESSURES ARE BASED ON THE LOWER OF THE PIPE RATING PER ANSI B31.3 OR THE CARBON STEEL/DUCTILE IRON CONNECTION RATING.
4) FOR PIPING SYSTEMS CONSISTING OF ALL STAINLESS STEEL COMPONENTS, PRESSURE RATINGS WILL BE LESS THAN THAT SHOWN ABOVE (CONTACT FACTORY).



TMI[®] Carbon Steel Pipe

Cold Drawn Seamless

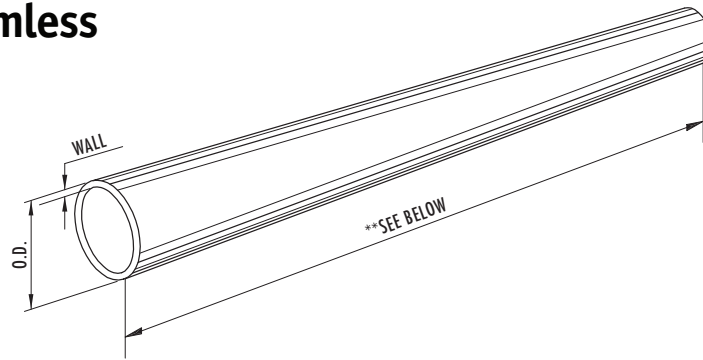

TMP52CD

A519-DIN 2391c St 52.4 NBK Phosphated High Quality Bendable Cold Drawn Seamless Carbon Steel

Schedule 40

Nominal Size	Pipe Part No.	OD x Wall (in)	Bore Dia. (in)	WT. lbs/ft	Working Pressure PSI (bar)
1/2"	TMP52CD-SCH40-050x**	0.840 x 0.109	0.622	0.85	6200 (430)
3/4"	TMP52CD-SCH40-075x**	1.050 x 0.113	0.824	1.13	5000 (345)
1"	TMP52CD-SCH40-100x**	1.315 x 0.133	1.049	1.68	4700 (325)
1 1/4"	TMP52CD-SCH40-125x**	1.660 x 0.140	1.380	2.27	3900 (270)
1 1/2"	TMP52CD-SCH40-150x**	1.900 x 0.145	1.610	2.72	3500 (240)
2"	TMP52CD-SCH40-200x**	2.375 x 0.154	2.067	3.65	2900 (200)

**INDICATE LENGTH (inches), AVAILABLE IN 240" OR 360" LENGTHS

Schedule 80

Nominal Size	Pipe Part No.	OD x Wall (in)	Bore Dia. (in)	WT. lbs/ft	Working Pressure PSI (bar)
1/2"	TMP52CD-SCH80-050x**	0.840 x 0.147	0.546	1.09	8600 (595)
3/4"	TMP52CD-SCH80-075x**	1.050 x 0.154	0.742	1.47	7000 (485)
1"	TMP52CD-SCH80-100x**	1.315 x 0.179	0.957	2.17	6500 (450)
1 1/4"	TMP52CD-SCH80-125x**	1.660 x 0.191	1.278	2.99	5400 (370)
1 1/2"	TMP52CD-SCH80-150x**	1.900 x 0.200	1.500	3.63	4900 (340)
2"	TMP52CD-SCH80-200x**	2.375 x 0.218	1.939	5.02	4200 (290)
2 1/2"	TMP52CD-SCH80-250x**	2.875 x 0.276	2.323	7.65	4500 (310)
3"	TMP52CD-SCH80-300x**	3.500 x 0.300	2.900	10.24	3900 (270)
4"	TMP52CD-SCH80-400x**	4.500 x 0.337	3.826	14.98	3420 (235)

**INDICATE LENGTH (inches), AVAILABLE IN 240" OR 360" LENGTHS

Schedule 160

Nominal Size	Pipe Part No.	OD x Wall (in)	Bore Dia. (in)	WT. lbs/ft	Working Pressure PSI (bar)
1 1/2"	TMP52CD-SCH160-150x**	1.900 x 0.281	1.338	4.86	6930 (478)
2"	TMP52CD-SCH160-200x**	2.375 x 0.343	1.689	7.44	6750 (465)
2 1/2"	TMP52CD-SCH160-250x**	2.875 x 0.375	2.125	10.01	6030 (415)

**INDICATE LENGTH (inches), AVAILABLE IN 240" OR 360" LENGTHS

Heavy Wall

Nominal Size	Pipe Part No.	OD x Wall (mm)	Bore Dia. (in)	WT. lbs/ft	Working Pressure PSI (bar)
1 1/2"	TMP52CD-56x150x**	56 x 8.5	1.54	6.70	7400 (510)
2"	TMP52CD-66x200x**	66 x 8.5	1.93	8.11	6100 (420)
2 1/2"	TMP52CD-80x250x**	80 x 10	2.36	11.62	5900 (410)
3"	TMP52CD-97x300x**	97 x 12	2.87	16.93	5900 (410)
4"	TMP52CD-115x400x**	115 x 15	3.35	24.90	6200 (430)

**INDICATE LENGTH (inches), AVAILABLE IN RANDOM LENGTHS UP TO 360"

- MAXIMUM ALLOWABLE WORKING PRESSURES ARE BASED ON THE PIPE RATING PER ANSI B31.3



TMI® Carbon Steel Pipe

Hot Rolled Seamless

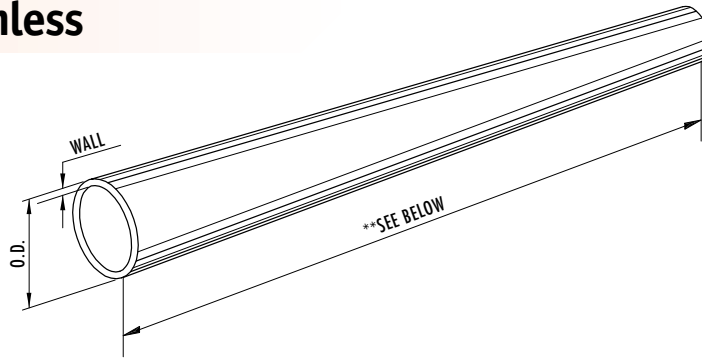

TMP44HR

A519 - Cleaned & Phosphated Seamless Carbon Steel

Schedule 40

Nominal Size	Pipe Part No.	OD x Wall (in)	Bore Dia. (in)	WT. lbs/ft	Working Pressure PSI (bar)
2 1/2"	TMP44HR-SCH40-250x**	2.875 x 0.203	2.469	5.79	2600 (180)
3"	TMP44HR-SCH40-300x**	3.500 x 0.216	3.068	7.57	2300 (160)
4"	TMP44HR-SCH40-400x**	4.500 x 0.237	4.026	10.78	1900 (130)
5"	TMP44HR-SCH40-500x**	5.563 x 0.258	5.047	14.60	1700 (115)
6"	TMP44HR-SCH40-600x**	6.625 x 0.280	6.065	18.95	1500 (105)
8"	TMP44HR-SCH40-800x**	8.625 x 0.322	7.981	28.52	1300 (90)

• FOR SIZES 10" OR LARGER CONSULT FACTORY

**INDICATE LENGTH (inches), SIZES 2 1/2" & 3" AVAILABLE IN 360" LENGTHS, SIZES 4" - 8" AVAILABLE IN RANDOM LENGTHS UP TO 480"

TMP106HR

A106B - Cleaned Seamless Carbon Steel

Schedule XXS/160

Nominal Size	Pipe Part No.	OD x Wall (in)	Bore Dia. (in)	WT. lbs/ft	Working Pressure PSI (bar)
5"	TMP106HR-SCHXXS-500x**	5.563 x 0.750	4.063	38.51	5200 (360)
6"	TMP106HR-SCHXXS-600x**	6.625 x 0.864	4.897	53.10	5000 (345)
8"	TMP106HR-SCH160-800x**	8.625 x 0.906	6.813	74.61	4100 (285)

• FOR SIZES 10" OR LARGER CONSULT FACTORY

**INDICATE LENGTH (inches), AVAILABLE IN RANDOM LENGTHS UP TO 480"

• MAXIMUM ALLOWABLE WORKING PRESSURES ARE BASED ON THE PIPE RATING PER ANSI B31.3



TMI[®] Stainless Steel Pipe

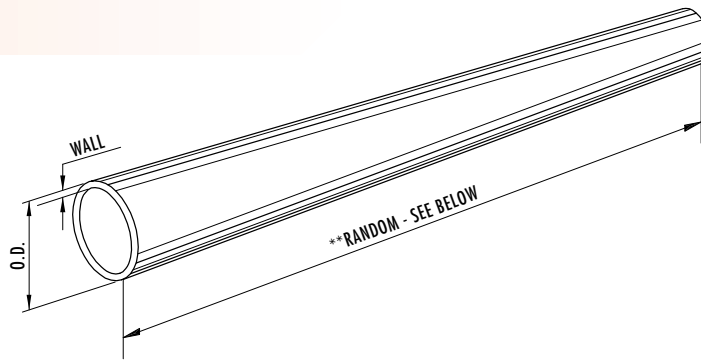

TMP304SS/316SS

A312-Seamless Stainless Steel (supplied as dual certification ie. 304/304L or 316/316L)

Schedule 40

Nominal Size	304/304L Stainless Steel Pipe Part No.	316/316L Stainless Steel Pipe Part No.	OD x Wall (in)	Bore Dia. (in)	WT. lbs/ft	Working Pressure PSI (bar)
1/2"	TMP304SS-SCH40-050x**	TMP316SS-SCH40-050x**	0.840 x 0.109	0.622	0.85	5000 (345)
3/4"	TMP304SS-SCH40-075x**	TMP316SS-SCH40-075x**	1.050 x 0.113	0.824	1.13	4100 (285)
1"	TMP304SS-SCH40-100x**	TMP316SS-SCH40-100x**	1.315 x 0.133	1.049	1.68	3800 (260)
1 1/4"	TMP304SS-SCH40-125x**	TMP316SS-SCH40-125x**	1.660 x 0.140	1.380	2.27	3100 (215)
1 1/2"	TMP304SS-SCH40-150x**	TMP316SS-SCH40-150x**	1.900 x 0.145	1.610	2.72	2800 (190)
2"	TMP304SS-SCH40-200x**	TMP316SS-SCH40-200x**	2.375 x 0.154	2.067	3.65	2400 (165)
2 1/2"	TMP304SS-SCH40-250x**	TMP316SS-SCH40-250x**	2.875 x 0.203	2.469	5.79	2600 (180)
3"	TMP304SS-SCH40-300x**	TMP316SS-SCH40-300x**	3.500 x 0.216	3.068	7.58	2300 (160)
4"	TMP304SS-SCH40-400x**	TMP316SS-SCH40-400x**	4.500 x 0.237	4.026	10.79	1900 (130)
5"	TMP304SS-SCH40-500x**	TMP316SS-SCH40-500x**	5.563 x 0.258	5.047	14.62	1700 (115)
6"	TMP304SS-SCH40-600x**	TMP316SS-SCH40-600x**	6.625 x 0.280	6.065	18.97	1500 (105)
8"	TMP304SS-SCH40-800x**	TMP316SS-SCH40-800x**	8.625 x 0.322	7.981	28.55	1300 (90)

• FOR SIZES 10" OR LARGER CONSULT FACTORY

**INDICATE LENGTH (inches), AVAILABLE IN RANDOM LENGTHS UP TO 240"

Schedule 80

Nominal Size	304/304L Stainless Steel Pipe Part No.	316/316L Stainless Steel Pipe Part No.	OD x Wall (in)	Bore Dia. (in)	WT. lbs/ft	Working Pressure PSI (bar)
1/2"	TMP304SS-SCH80-050x**	TMP316SS-SCH80-050x**	0.840 x 0.147	0.546	1.09	7000 (485)
3/4"	TMP304SS-SCH80-075x**	TMP316SS-SCH80-075x**	1.050 x 0.154	0.742	1.47	5700 (390)
1"	TMP304SS-SCH80-100x**	TMP316SS-SCH80-100x**	1.315 x 0.179	0.957	2.17	5300 (365)
1 1/4"	TMP304SS-SCH80-125x**	TMP316SS-SCH80-125x**	1.660 x 0.191	1.278	2.99	4400 (300)
1 1/2"	TMP304SS-SCH80-150x**	TMP316SS-SCH80-150x**	1.900 x 0.200	1.500	3.63	4000 (275)
2"	TMP304SS-SCH80-200x**	TMP316SS-SCH80-200x**	2.375 x 0.218	1.939	5.02	3400 (235)
2 1/2"	TMP304SS-SCH80-250x**	TMP316SS-SCH80-250x**	2.875 x 0.276	2.323	7.65	3600 (250)
3"	TMP304SS-SCH80-300x**	TMP316SS-SCH80-300x**	3.500 x 0.300	2.900	10.24	3200 (220)

**INDICATE LENGTH (inches), AVAILABLE IN RANDOM LENGTHS UP TO 240"

• MAXIMUM ALLOWABLE WORKING PRESSURES ARE BASED ON THE PIPE RATING PER ANSI B31.3



TMI[®] Stainless Steel Pipe

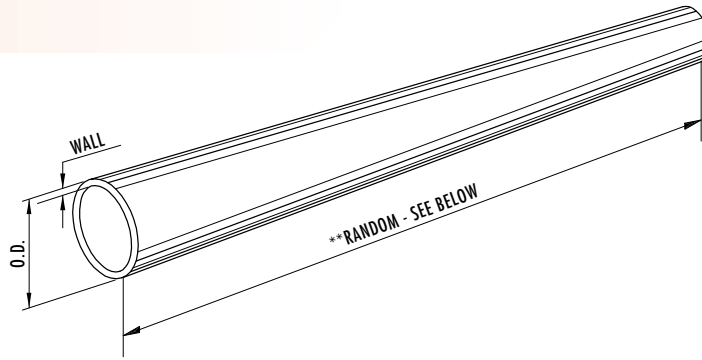

TMP2205SS

A790 - Seamless Duplex Stainless Steel

Schedule 80

Nominal Size	Pipe Part No.	OD x Wall (in)	Bore Dia. (in)	WT. lbs/ft	Working Pressure PSI (bar)
1 1/4"	TMP2205SS-SCH80-125x**	1.660 x 0.191	1.278	2.99	6600 (455)
1 1/2"	TMP2205SS-SCH80-150x**	1.900 x 0.200	1.500	3.63	6000 (420)
2"	TMP2205SS-SCH80-200x**	2.375 x 0.218	1.939	5.02	5200 (360)

**INDICATE LENGTH (inches), AVAILABLE IN RANDOM LENGTHS UP TO 240"

TMP304SS/316SS

A312 - Seamless Stainless Steel (supplied as dual certification ie. 304/304L or 316/316L)

Schedule XXS/160

Nominal Size	304/304L Stainless Steel Pipe Part No.	316/316L Stainless Steel Pipe Part No.	OD x Wall (in)	Bore Dia. (in)	WT. lbs/ft	Working Pressure PSI (bar)
4"	TMP304SS-SCHXXS-400x**	TMP316SS-SCHXXS-400x**	4.500 x 0.674	3.152	27.54	5800 (400)
5"	TMP304SS-SCHXXS-500x**	TMP316SS-SCHXXS-500x**	5.563 x 0.750	4.063	38.55	5200 (360)
6"	TMP304SS-SCHXXS-600x**	TMP316SS-SCHXXS-600x**	6.625 x 0.864	4.897	53.16	5000 (345)
8"	TMP304SS-SCH160-800x**	TMP316SS-SCH160-800x**	8.625 x 0.906	6.813	74.69	4000 (275)

• FOR SIZES 10" OR LARGER CONSULT FACTORY

**INDICATE LENGTH (inches), AVAILABLE IN RANDOM LENGTHS UP TO 240"

• MAXIMUM ALLOWABLE WORKING PRESSURES ARE BASED ON THE PIPE RATING PER ANSI B31.3



