

PYPLOK® Tooling

The PYPLOK® Tooling System Consists of the Following Items

- Tube-Mac® Swage Tooling
- 10,000 PSI/690 bar Hydraulic Power Supply
- Inspection/Marking Gauges

Swage Tooling

The tools are lightweight, portable and activated by 10,000 PSI/690 bar hydraulic pressure. The swage tools are identical in design. The only difference is the force generated by each model.

The following models are used to install the PYPLOK® fittings:

DLT10 – 1/4" OD and 6mm-8mm

DLT20 – 1/4"-3/8" NPS, 1/4"-5/8" OD and 6mm-16mm

DLT40 – 1/4"-3/4" NPS, 3/8"-1" OD and 8mm-30mm

DLT55 – 1/2"-1-1/2" NPS, 1"-2" OD and 22mm-57mm

DLT70 – 1"-3" NPS, 1-1/2"-2" OD and 35mm-76mm

DLT86 – 3"-4" NPS

Swage Tooling Primary Components

The PYPLOK® swage tooling assembly has four main components:

- Power Unit
- Head Assembly
- Swage Dies
- Die Block Assembly

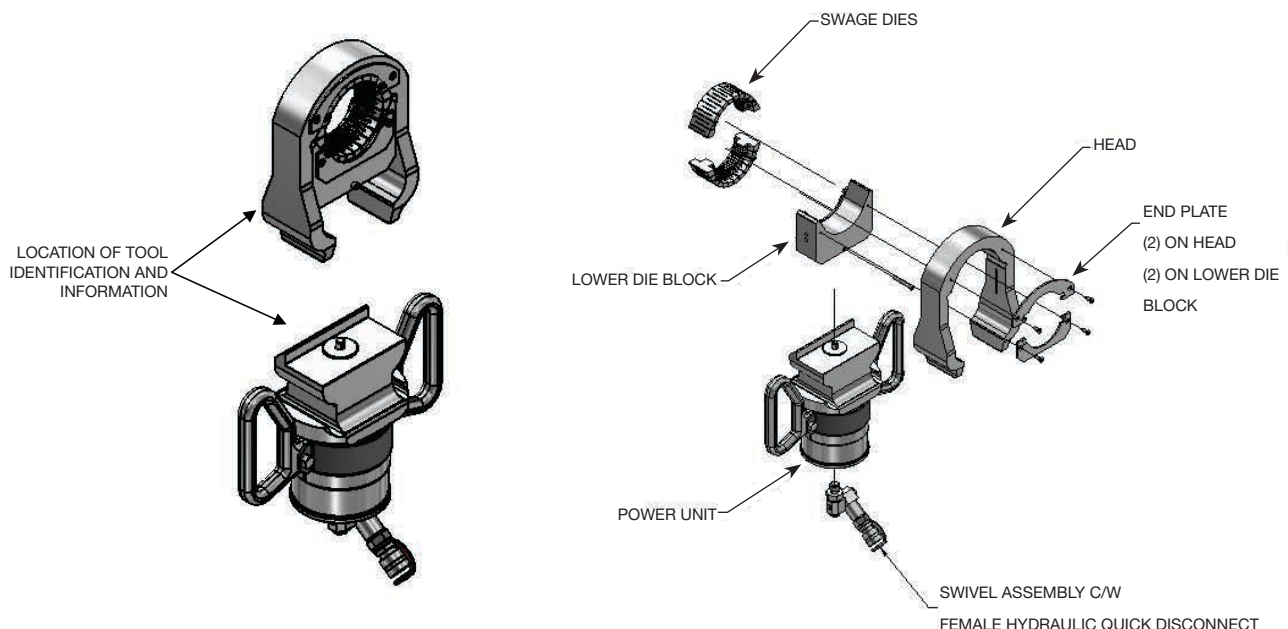

PYPLOK® Tooling Dimensions

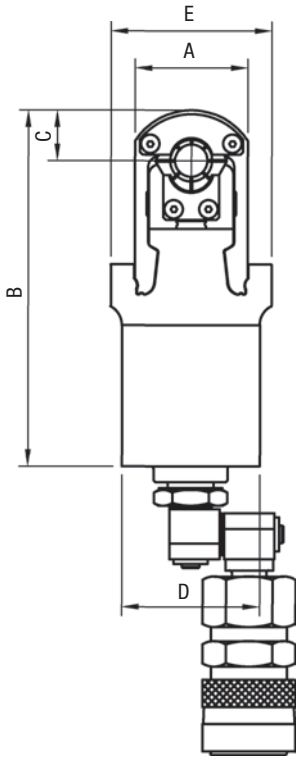

Model 10

Head Size	Dimensions - Inch (mm)				
	A	B	C	D	E
01' Series	1.33 (33.86)	4.22 (107.21)	0.60 (15.24)	1.63 (41.40)	1.90 (48.26)

Head Size	Weight - lbs (kg)		
	Power Unit	Head Assembly	Complete Tool
01' Series	2.00 (0.90)	0.03 (0.20)	2.40 (1.10)

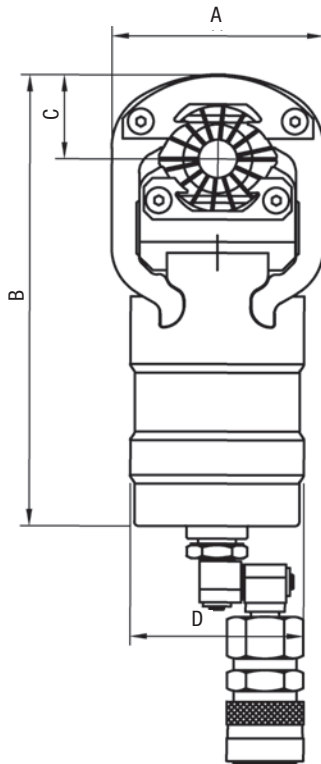

Model 20

Head Size	Dimensions - Inch (mm)			
	A	B	C	D
00' Series	3.04 (77.22)	6.48 (164.67)	1.21 (30.84)	2.49 (63.25)

Head Size	Weight - lbs (kg)		
	Power Unit	Head Assembly	Complete Tool
00' Series	4.40 (2.00)	3.10 (1.40)	7.50 (3.40)

PYPLOK® Tooling Dimensions

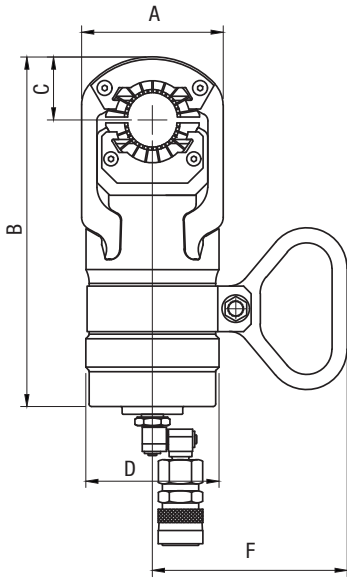

*Model 40

Head Size	Dimensions - Inch (mm)				
	A	B	C	D	F
00' Series	3.29 (83.57)	8.23 (209.12)	1.15 (29.26)	3.29 (83.59)	4.81 (122.23)
02' Series	3.50 (88.88)	8.63 (219.28)	1.55 (39.45)	3.29 (83.59)	4.81 (122.23)

Head Size	Weight - lbs (kg)		
	Power Unit	Head Assembly	Complete Tool
00' Series	9.20 (4.20)	4.20 (1.90)	13.40 (6.10)
02' Series	9.20 (4.20)	5.30 (2.40)	14.60 (6.60)

*Handle is an option. Not standard with model 40.

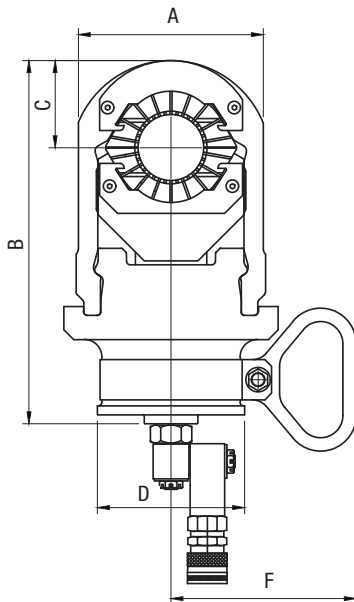

*Model 55

Head Size	Dimensions - Inch (mm)				
	A	B	C	D	F
01' Series	5.18 (131.57)	9.92 (251.92)	2.43 (61.70)	4.12 (104.65)	5.19 (131.78)

Head Size	Weight - lbs (kg)		
	Power Unit	Head Assembly	Complete Tool
01' Series	16.70 (7.60)	11.20 (5.10)	27.90 (12.70)

*Handle is an option. Not standard with model 55.

PYPLOK® Tooling Dimensions

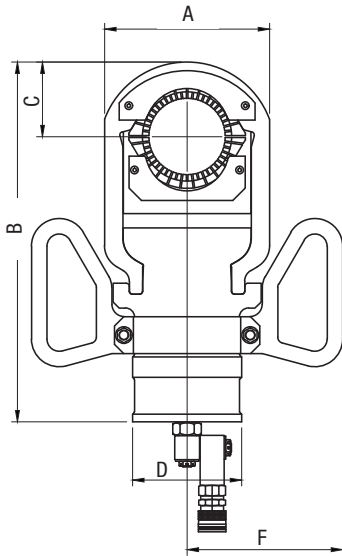

*Model 70

Head Size	Dimensions - Inch (mm)				
	A	B	C	D	F
01' Series	6.68 (169.70)	14.62 (371.45)	3.03 (76.99)	4.41 (112.07)	6.30 (159.97)
02' Series	7.55 (191.77)	15.23 (386.77)	3.62 (92.05)	4.41 (112.07)	6.30 (159.97)

Head Size	Weight - lbs (kg)		
	Power Unit	Head Assembly	Complete Tool
01' Series	30.80 (14.00)	17.60 (8.00)	48.40 (22.00)
02' Series	30.80 (14.00)	23.10 (10.50)	53.90 (24.50)

*Handle comes standard with model 70.

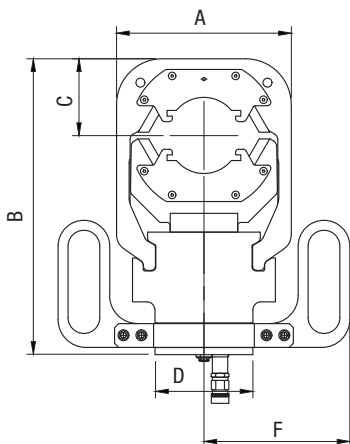

*Model 86

Head Size	Dimensions - Inch (mm)				
	A	B	C	D	F
00' Series	11.00 (279.40)	19.50 (495.30)	5.00 (127.00)	6.25 (158.75)	18.00 (457.20)

Head Size	Weight - lbs (kg)		
	Power Unit	Head Assembly	Complete Tool
00' Series	61.70 (28.00)	62.20 (28.20)	123.90 (56.20)

*Handle comes standard with model 86.

PYPLOK® Tooling Size Range Coverage

DM 20 Series - NPS Pipe									
	1/4"	3/8"	1/2"	3/4"	1"	1-1/4"	1-1/2"	2"	3"
Model 20									
Model 40									
Model 55									
Model 70									
Model 86									

DM 60 Series - OD Tube									
	1/4"	3/8"	1/2"	5/8"	3/4"	1"	1-1/4"	1-1/2"	2"
Model 10									
Model 20									
Model 40									
Model 55									
Model 70									

DM 80 Series - Metric Tube																	
	6mm	8mm	10mm	12mm	15mm	16mm	18mm	20mm	22mm	25mm	28mm	30mm	35mm	38mm	42mm	50mm	60mm
Model 10																	
Model 20																	
Model 40																	
Model 55																	
Model 70																	

DP 40N Series - NPS Low Pressure			
	2-1/2"	3"	4"
Model 70			
Model 86			

DP 40M Series - Metric Low Pressure		
	44.5mm	57mm
Model 55		

Introduction

Technical Information

DM 20 – NPS Pipe

DM 60 – OD Tube

DM 80 – Metric & JIS Tube

DP 40N – NPS Low Pressure

DP 40M – Metric Low Pressure

PYPLOK® Tooling

Installation Procedures

Appendix

PYPLOK® Tool Matrix

DM 20 Series - NPS Pipe

Model 40 Power Unit - DLT40MAPW0000

Size	Fitting Series	Inspection Gauge	Die Set	Die Block	Head	Upper Endplates	Lower Endplates	Endplate Bolts	*Head Assembly
Model 40-00' Series									MS51595-61 10-24 x 3/8" Flat Socket Cap
1/4"	DM 20 Series	DLT40PYIG3804	DLT40PYDI3804	DLT40MADA0000	DLT40MAHD0000	DLT40PYEU0000	DLT40PYEL0000	DLT40PYHA3804	
3/8"		DLT40PYIG3806	DLT40PYDI3806					DLT40PYHA3806	
Model 40 - 02' Series									
1/2"	DM 20 Series	DLT40PYIG3808	DLT40PYDI3808	DLT40MADA0002	DLT40MAHD0002	DLT40PYEU0002	DLT40PYEL0002	DLT40PYHA3808	
3/4"		DLT40PYIG3812	DLT40PYDI3812					DLT40PYHA3812	

Model 55 Power Unit - DLT55MAPW0000

Size	Fitting Series	Inspection Gauge	Die Set	Die Block	Head	Upper Endplates	Lower Endplates	Endplate Bolts	*Head Assembly
Model 55 - 01' Series									MS51595-61 10-24 x 3/8" Flat Socket Cap
1/2"	DM 20 Series	DLT40PYIG3808	DLT55PYDI3808	DLT55MADA0001	DLT55MAHD0001	DLT55PYEU0001	DLT55PYEL0001	DLT55PYHA3808	
3/4"		DLT40PYIG3812	DLT55PYDI3812					DLT55PYHA3812	
1"		DLT55PYIG3816	DLT55PYDI3816					DLT55PYHA3816	
1-1/4"		DLT55PYIG3820	DLT55PYDI3820					DLT55PYHA3820	
1-1/2"		DLT55PYIG3824	DLT55PYDI3824					DLT55PYHA3824	

Model 70 Power Unit - DLT70MAPW0000

Size	Fitting Series	Inspection Gauge	Die Set	Die Block	Head	Upper Endplates	Lower Endplates	Endplate Bolts	*Head Assembly
Model 70 - 01' Series									MS51595-61 10-24 x 3/8" Flat Socket Cap
1"	DM 20 Series	DLT55PYIG3816	DLT70PYDI3816	DLT70MADA0001	DLT70MAHD0001	DLT70PYEU0001	DLT70PYEL0001	DLT70PYHA3816	
1-1/4"		DLT55PYIG3820	DLT70PYDI3820					DLT70PYHA3820	
1-1/2"		DLT55PYIG3824	DLT70PYDI3824					DLT70PYHA3824	
2"		DLT70PYIG3832	DLT70PYDI3832					DLT70PYHA3832	

Model 86 Power Unit - DLT86MAPW0000

Size	Fitting Series	Inspection Gauge	Die Set	Die Block	Head	Upper Endplates	Lower Endplates	Endplate Bolts	*Head Assembly
Model 86 - 00' Series									1/4-28 x 1/2" Socket Cap
3"	DM 20 Series	DLT86PYIG3848	DLT86PYDI3848	DLT86MADA0000	DLT86MAHD0000	DLT86PYEU0001	DLT86PYEL0001	DLT86PYHA3848	

*Head Assembly Includes: Die Set, Die Block, Head, Endplates and Endplate Bolts

PYPLOK® Tool Matrix

DM 60 Series - OD Tube

Model 10 Power Unit - DLT10MAPW0000

Size	Fitting Series	Inspection Gauge	Die Set	Die Block	Head	Upper Inboard	Upper Outboard	Lower Inboard	Lower Outboard	*Head Assembly
Model 10 - 01' Series										
1/4"	DM 60 Series	DLT10PYIG3704	DLT10PYDI3704	DLT10MADA0001	DLT10MAHD0001	DLT10PSEU4006	DLT10PYFU704	DLT10PSEL4006	DLT10PSFL4006	DLT10PYHA3704

Model 20 Power Unit - DLT20MAPW0000

Size	Fitting Series	Inspection Gauge	Die Set	Die Block	Head	Upper Endplates	Lower Endplates	Endplate Bolts	*Head Assembly
Model 20 - 00' Series									
3/8"	DM 60 Series	DLT40PYIG3706	DLT20PYDI3706	DLT20MADA0001	DLT20MADA0000	DLT40PYEU0000	DLT40PYEL0000	MS51595-61 10-24 x 3/8" Flat Socket Cap	DLT20PYHA3706
1/2"		DLT40PYIG3708	DLT20PYDI3708						DLT20PYHA3708
5/8"		DLT40PYIG3710	DLT20PYDI3916						DLT20PYHA3916

Model 40 Power Unit - DLT40MAPW0000

Size	Fitting Series	Inspection Gauge	Die Set	Die Block	Head	Upper Endplates	Lower Endplates	Endplate Bolts	*Head Assembly
Model 40 - 00' Series									
3/8"	DM 60 Series	DLT40PYIG3706	DLT40PYDI3706	DLT40MADA0000	DLT40MAHD0000	DLT40PYEU0000	DLT40PYEL0000	MS51595-61 10-24 x 3/8" Flat Socket Cap	DLT40PYHA3706
1/2"		DLT40PYIG3708	DLT40PYDI3708						DLT40PYHA3708
5/8"		DLT40PYIG3710	DLT40PYDI3916						DLT40PYHA3916
Model 40 - 02' Series									
3/4"	DM 60 Series	DLT40PYIG3712	DLT40PYDI3712	DLT40MADA0002	DLT40MAHD0002	DLT40PYEU0002	DLT40PYEL0002		DLT40PYHA3712
1"		DLT40PYIG3716	DLT40PYDI3716						DLT40PYHA3716

Model 55 Power Unit - DLT55MAPW0000

Size	Fitting Series	Inspection Gauge	Die Set	Die Block	Head	Upper Endplates	Lower Endplates	Endplate Bolts	*Head Assembly
Model 55 - 01' Series									
1"	DM 60 Series	DLT40PYIG3716	DLT55PYDI3716	DLT55MADA0001	DLT55MAHD0001	DLT55PYEU0001	DLT55PYEL0001	MS51595-61 10-24 x 3/8" Flat Socket Cap	DLT55PYHA3716
1-1/4"		DLT55PYIG3720	DLT55PYDI3720						DLT55PYHA3720
1-1/2"		DLT55PYIG3938	DLT55PYDI3938						DLT55PYHA3938
2"		DLT55PYIG3732	DLT55PYDI3824						DLT55PYHA3824

*Head Assembly Includes: Die Set, Die Block, Head, Endplates and Endplate Bolts

PYPLOK® Tool Matrix

DM 80 Series - Metric Tube

Model 10 Power Unit - DLT10MAPW0000										
Size	Fitting Series	Inspection Gauge	Die Set	Die Block	Head	Upper Inboard	Upper Outboard	Lower Inboard	Lower Outboard	*Head Assembly
Model 10 - 01' Series										
6mm	DM 80 Series	DLT10PYIG3906	DLT10PYDI3704	DLT10MADA0001	DLT10MAHD0001	DLT10PSEU4006	DLT10PYFU704	DLT10PSEL4006	DLT10PSFL4006	DLT10PYHA3704
8mm		DLT10PYIG3908	DLT10PYDI3908							DLT10PYHA3908

Model 20 Power Unit - DLT20MAPW0000										
Size	Fitting Series	Inspection Gauge	Die Set	Die Block	Head	Upper Endplates	Lower Endplates	Endplate Bolts	*Head Assembly	
Model 20 - 00' Series										
8mm	DM 80 Series	DLT40PYIG3908	DLT20PYDI3908	DLT20MADA0000	DLT20MAHD0000	DLT40PYEU0000	DLT40PYEL0000	MS51595-61 10-24 x 3/8" Flat Socket Cap	DLT20PYHA3908	
10mm		DLT40PYIG3910	DLT20PYDI3910						DLT20PYHA3910	
12mm		DLT40PYIG3912	DLT20PYDI3912						DLT20PYHA3912	
15mm		DLT40PYIG3915	DLT20PYDI3916						DLT20PYHA3916	
16mm		DLT40PYIG3916	DLT20PYDI3916						DLT20PYHA3916	

Model 40 Power Unit - DLT40MAPW0000										
Size	Fitting Series	Inspection Gauge	Die Set	Die Block	Head	Upper Endplates	Lower Endplates	Endplate Bolts	*Head Assembly	
Model 40 - 00' Series										
8mm	DM 80 Series	DLT40PYIG3908	DLT20PYDI3908	DLT40MADA0000	DLT40MAHD0000	DLT40PYEU0000	DLT40PYEL0000	MS51595-61 10-24 x 3/8" Flat Socket Cap	DLT40PYHA3908	
10mm		DLT40PYIG3910	DLT40PYDI3910						DLT40PYHA3910	
12mm		DLT40PYIG3912	DLT40PYDI3912						DLT40PYHA3912	
14mm		DLT40PYIG3914	DLT40PYDI3804						DLT40PYHA3804	
15mm		DLT40PYIG3915	DLT40PYDI3916						DLT40PYHA3916	
16mm		DLT40PYIG3916	DLT40PYDI3916						DLT40PYHA3916	
18mm		DLT40PYIG3918	DLT40PYDI3806						DLT40PYHA3806	
20mm		DLT40PYIG3920	DLT40PYDI3920						DLT40PYHA3920	
Model 40 - 02' Series										
22mm	DM 80 Series	DLT40PYIG3922	DLT40PYDI3808	DLT40MADA0002	DLT40MAHD0002	DLT40PYEU0002	DLT40PYEL0002	MS51595-61 10-24 x 3/8" Flat Socket Cap	DLT40PYHA3808	
25mm		DLT40PYIG3925	DLT40PYDI3925						DLT40PYHA3925	
28mm		DLT40PYIG3928	DLT40PYDI3812						DLT40PYHA3812	
30mm		DLT40PYIG3930	DLT40PYDI3930						DLT40PYHA3930	

*Head Assembly Includes: Die Set, Die Block, Head, Endplates and Endplate Bolts

PYPLOK® Tool Matrix

DM 80 Series - Metric Tube

Model 55 Power Unit - DLT55MAPW0000

Size	Fitting Series	Inspection Gauge	Die Set	Die Block	Head	Upper Endplates	Lower Endplates	Endplate Bolts	*Head Assembly
Model 55 - 01' Series									
22mm	DM 80 Series	DLT40PYIG3922	DLT55PYDI3808	DLT55MADA0001	DLT55MAHD0001	DLT55PYEU0001	DLT55PYEU0001	MS51595-61 10-24 x 3/8" Flat Socket Cap	DLT55PYHA3808
25mm		DLT40PYIG3925	DLT55PYDI3925						DLT55PYHA3925
28mm		DLT40PYIG3928	DLT55PYDI3812						DLT55PYHA3812
30mm		DLT40PYIG3930	DLT55PYDI3930						DLT55PYHA3930
35mm		DLT55PYIG3935	DLT55PYDI3816						DLT55PYHA3816
38mm		DLT55PYIG3938	DLT55PYDI3938						DLT55PYHA3938
42mm		DLT55PYIG3820	DLT55PYDI3820						DLT55PYHA3820
50mm		DLT55PYIG3950	DLT55PYDI3824						DLT55PYHA3824

Model 70 Power Unit - DLT70MAPW0000

Size	Fitting Series	Inspection Gauge	Die Set	Die Block	Head	Upper Endplates	Lower Endplates	Endplate Bolts	*Head Assembly
Model 70 - 01' Series									
35mm	DM 80 Series	DLT55PYIG3935	DLT70PYDI3816	DLT70MADA0001	DLT70MAHD0001	DLT70PYEU0001	DLT70PYEL0001	MS51595-61 10-24 x 3/8" Flat Socket Cap	DLT70PYHA3816
38mm		DLT55PYIG3938	DLT70PYDI3938						DLT70PYHA3938
42mm		DLT55PYIG3820	DLT70PYDI3820						DLT70PYHA3820
50mm		DLT55PYIG3950	DLT70PYDI3824						DLT70PYHA3824
60mm		DLT70PYIG3832	DLT70PYDI3832						DLT70PYHA3832

*Head Assembly Includes: Die Set, Die Block, Head, Endplates and Endplate Bolts

Introduction

Technical Information

DM 20 – NPS Pipe

DM 60 – OD Tube

DM 80 – Metric & JIS Tube

DP 40N – NPS Low Pressure

DP 40M – Metric Low Pressure

PYPLOK® Tooling

Installation Procedures

Appendix

PYPLOK® Tool Matrix

DM 80 Series - JIS Metric Tube

Model 40 Power Unit - DLT40MAPW0000

Size	Fitting Series	Inspection Gauge	Die Set	Die Block	Head	Upper Endplates	Lower Endplates	Endplate Bolts	*Head Assembly
Model 40-00' Series									MS51595-61 10-24 x 3/8" Flat Socket Cap
1/4"	08A	DLT40PYIG3908A	DLT40PYDI3804	DLT40MADA0000	DLT40MAHD0000	DLT40PYEU0000	DLT40PYEL0000	DLT40PYHA3804	
3/8"	10A	DLT40PYIG3910A	DLT40PYDI3806					DLT40PYHA3806	
Model 40 - 02' Series									
1/2"	15A	DLT40PYIG3915A	DLT40PYDI3808	DLT40MADA0002	DLT40MAHD0002	DLT40PYEU0002	DLT40PYEL0002	DLT40PYHA3808	
3/4"	20A	DLT40PYIG3920A	DLT40PYDI3812					DLT40PYHA3812	

Model 55 Power Unit - DLT55MAPW0000

Size	Fitting Series	Inspection Gauge	Die Set	Die Block	Head	Upper Endplates	Lower Endplates	Endplate Bolts	*Head Assembly
Model 55 - 01' Series									MS51595-61 10-24 x 3/8" Flat Socket Cap
1/2"	15A	DLT40PYIG3915A	DLT55PYDI3808	DLT55MADA0001	DLT55MAHD0001	DLT55PYEU0001	DLT55PYEL0001	DLT55PYHA3808	
3/4"	20A	DLT40PYIG3920A	DLT55PYDI3812					DLT55PYHA3812	
1"	25A	DLT55PYIG3925A	DLT55PYDI3816					DLT55PYHA3816	
1-1/4"	32A	DLT55PYIG3932A	DLT55PYDI3820					DLT55PYHA3820	
1-1/2"	40A	DLT55PYIG3940A	DLT55PYDI3824					DLT55PYHA3824	

Model 70 Power Unit - DLT70MAPW0000

Size	Fitting Series	Inspection Gauge	Die Set	Die Block	Head	Upper Endplates	Lower Endplates	Endplate Bolts	*Head Assembly
Model 70 - 01' Series									MS51595-61 10-24 x 3/8" Flat Socket Cap
1"	25A	DLT55PYIG3925A	DLT70PYDI3816	DLT70MADA0001	DLT70MAHD0001	DLT70PYEU0001	DLT70PYEL0001	DLT70PYHA3816	
1-1/4"	32A	DLT55PYIG3932A	DLT70PYDI3820					DLT70PYHA3820	
1-1/2"	40A	DLT55PYIG3940A	DLT70PYDI3824					DLT70PYHA3824	
2"	50A	DLT70PYIG3950A	DLT70PYDI3832					DLT70PYHA3832	

*Head Assembly Includes: Die Set, Die Block, Head, Endplates and Endplate Bolts

PYPLOK® Tool Matrix

DP 40N Series - NPS Low Pressure

Model 70 Power Unit - DLT70MAPW0000									
Size	Fitting Series	Inspection Gauge	Die Set	Die Block	Head	Upper Endplates	Lower Endplates	Endplate Bolts	*Head Assembly
Model 70 - 02' Series									
2-1/2"	DP 40N Series	DLT70PYIG4040	DLT70PYDI4040	DLT70MADA0002	DLT70MAHD0002	DLT70PYEU0002	DLT70PYEL0002	MS51595-61 10-24 x 3/8" Flat Socket Cap	DLT70PYHA4040
3"		DLT70PYIG4048	DLT70PYDI4048						DLT70PYHA4048

Model 86 Power Unit - DLT86MAPW0000									
Size	Fitting Series	Inspection Gauge	Die Set	Die Block	Head	Upper Endplates	Lower Endplates	Endplate Bolts	*Head Assembly
Model 86 - 00' Series									
4"	DP 40N Series	DLT86PYIG4064	DLT86PYDI4064	DLT86MADA0000	DLT86MAHD0000	DLT86PYEP0001	DLT86PYEP0001	1/4-28 x 1/2" Socket Cap	DLT86PYHA4064

*Head Assembly Includes: Die Set, Die Block, Head, Endplates and Endplate Bolts

DP 40M Series - Metric Low Pressure

Model 55 Power Unit - DLT55MAPW0000									
Size	Fitting Series	Inspection Gauge	Die Set	Die Block	Head	Upper Endplates	Lower Endplates	Endplate Bolts	*Head Assembly
Model 55 - 01' Series									
44.5mm	DP 40M Series	DLT55PYIG4244	DLT55PYDI3944	DLT55MADA0001	DLT55MAHD0001	DLT55PYEU0001	DLT55PYEL0001	MS51595-61 10-24 x 3/8" Flat Socket Cap	DLT55PYHA3944
57mm		DLT55PYIG4257	DLT55PYDI3957						DLT55PYHA3957

*Head Assembly Includes: Die Set, Die Block, Head, Endplates and Endplate Bolts

PYPLOK® Tooling

PYPLOK® Tooling CE Compliance

The PYPLOK® swage tooling assembly has four main components:

- Power Unit
- Head Assembly
- Swage Dies
- Die Block Assembly

PYPLOK® Swaging Tool Pump Requirements

1. Depending on application and environment the choice of Electric, Battery, Pneumatic or Hand Operated pumps can be used.
2. The hydraulic pumps used for operation of the PYPLOK® Tooling must be capable of producing up to but not exceeding 10,000 PSI/690 bar and have internal relief valve to prevent pump from producing more than 10,000 PSI/690 bar within the PYPLOK® Tools.
3. Power operated pumps must operate in hold-to-run mode (hydraulic supply only as long as push-button or pedal is activated, hydraulic Stop or Release when push-button or pedal are released). PYPLOK® has defined PL = c (EN ISO 13849) as requirement for the control circuit.
4. The hydraulic hose and quick connectors joining the pump to the PYPLOK® Tooling must be rated for use with a 10,000 PSI/690 bar Pump.

Pumps Offered by Tube-Mac® for Use with the PYPLOK® Tooling

Part Number	Description	Weight lbs (kg)
P392	Hand Pump	9.00 (4.10)
XA11G	Pneumatic Pump	19.40 (8.80)
PUD1100EU102	220 Volt Electric Pump	31.00 (14.05)
PUD1100BU112	110 Volt Electric Pump	31.00 (14.05)
B68M-P18	Battery Pump, 110V Charger	20.28 (9.20)
B68M-P18-220	Battery Pump, 220V Charger	20.28 (9.20)

Pumps come complete with carrying case and a 10 ft., 10,000 PSI/690 bar, non-conductive hose



PYPLOK® Tooling Accessories

PYPLOK® Tooling Accessories

DLT10PYCC1200	Case for (1) Model 10 Power Unit and (2) Head Assemblies
DLT20PYCC1200	Case for (1) Model 20 Power Unit and (2) Head Assemblies
DLT40PYCC1501	Case for (1) Model 40 Power Unit and (6) Head Assemblies
DLT55PYCC1501	Case for (1) Model 55 Power Unit and (1) Head Assembly
DLT55PYCC1502	Case for (2) Model 55 Head Assemblies
DLT70PYCC1501	Case for (1) Model 70 Power Unit
DLT70PYCC1502	Case for (2) Model 70 Head Assemblies
DLT70PYCC1503	Case for (1) Model 70 3" Head Assembly
DLT86PYCC0001	Case for (1) Model 86 Power Unit
DLT86PYCC0002	Case for (1) Model 86 Head Assembly
DLTXXPYSL0000	Swage Lube
DLT00HOSE0010	10' Hose Assembly comes with Quick Disconnects
DLT00HOSE0015	15' Hose Assembly comes with Quick Disconnects
DLT00SABP1040	Quick Disconnect Swivel Assembly for Model 10/20/40
DLT00SABP5570	Quick Disconnect Swivel Assembly for Model 55/70

Spare Endplates and Bolts

DLT10PYFU3704	Model 10 - Upper Out Endplate
DLT10PSEU4006	Model 10 - Upper In Endplate
DLT10PSFL4006	Model 10 - Lower Out Endplate
DLT10PSEL4006	Model 10 - Lower In Endplate
DLT20PYEU0000	Model 20 - Upper Endplate
DLT20PYEL0000	Model 20 - Lower Endplate
DLT40PYEU0000	Model 40 - 00' Series Upper Endplate
DLT40PYEL0000	Model 40 - 00' Series Lower Endplate
DLT40PYEU0002	Model 40 - 02' Series Upper Endplate
DLT40PYEL0002	Model 40 - 02' Series Lower Endplate
DLT55PYEU0001	Model 55 - Upper Endplate
DLT55PYEL0001	Model 55 - Lower Endplate
DLT70PYEU0001	Model 70 - 01' Series Upper Endplate
DLT70PYEL0001	Model 70 - 01' Series Lower Endplate
DLT70PYEU0002	Model 70 - 02' Series Upper Endplate
DLT70PYEL0002	Model 70 - 02' Series Lower Endplate
DLT86PYEP0001	Model 86 - Upper/Lower Endplate
10-24 x 3/8"	Flat Socket Cap Bolts for Model 20/40/55/70 Endplates
1/4-28 x 1/2"	Socket Cap Bolts for Model 86 Endplates

Optional Safety Endplates and Handles

DLT40PSPA000	Model 40 - 00' Series Upper Safety Endplate Kit
DLT40PSPA0002	Model 40 - 02' Series Upper Safety Endplate Kit
DLT55PSPA0001	Model 55 - Series Upper Safety Endplate Kit
DLT70PSPA0001	Model 70 - 01' Series Upper Safety Endplate Kit
DLT70PSPA0002	Model 70 - 02' Series Upper Safety Endplate Kit
DLT00PHLA4055	Model 40/55 Handle Kit
DLT70PHLA0000	Model 70 Handle Kit
DLT40PHLA0000	Model 40 Handle K
DLT55PHLA0000	Model 55 Handle Kit
DLT70PHLA0000	Model 70 Handle Kit

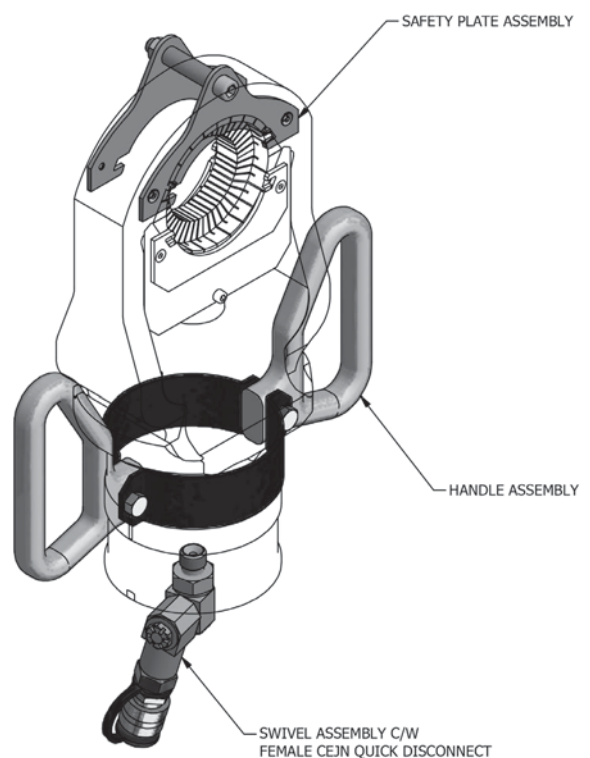

Introduction

Technical Information

DM 20 – NPS Pipe

DM 60 – OD Tube

DM 80 – Metric & JIS Tube

DP 40N – NPS Low Pressure

DP 40M – Metric Low Pressure

PYPLOK® Tooling

Installation Procedures

Appendix

H13

