

16 bar, 90° Flare Reference Guide

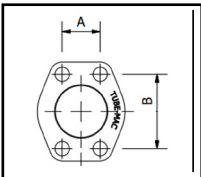

**90° Flare Flange
Dimensions**
Page D1



**90° Flare Flange
Clearance Holes
Metric only**
FFCN14, FFCN34, FFCN18
Page D2

16 bar 90° Flare Flange Dimensions

1/2" through 5" Flange pattern according to SAE J518 Code 61 (ISO 6162-1)

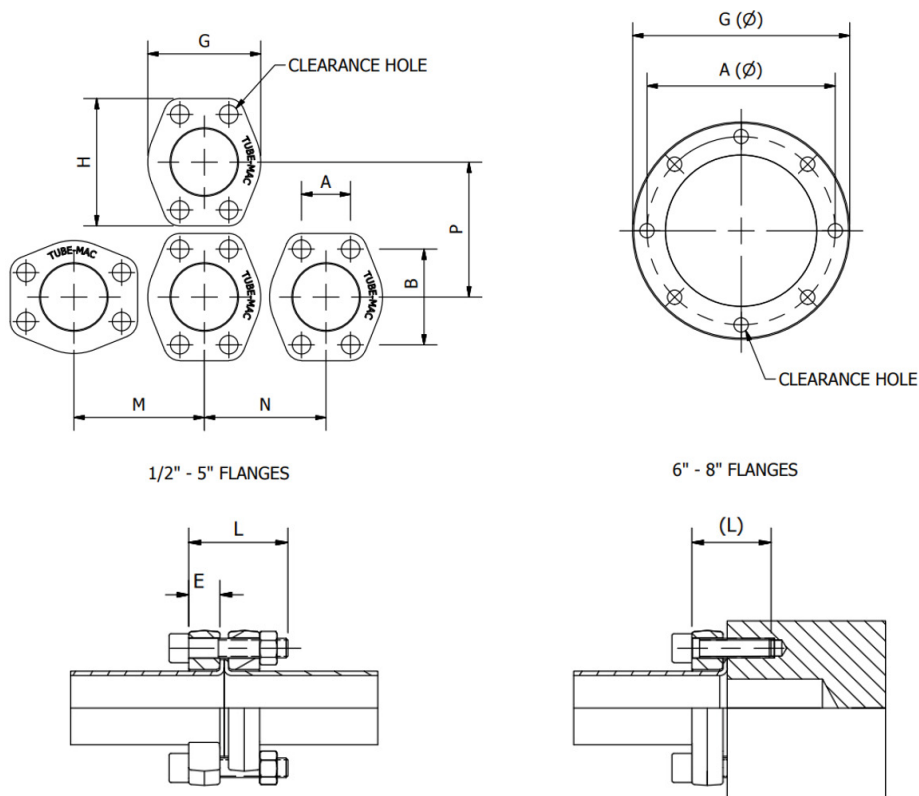

Metric Flange Dimensions (Millimeters) Only available in Metric Sizes										
Size	Dimensions (mm)								SHCS Bolt (mm)* L (L)	Working Pressure PSI (bar)
	A	B	G	H	M	N	P	E		
1/2"	17.5	38.1	46.0	56.9	52.1	49.0	58.9	20	M8 x 55 (40)	230 (16)
3/4"	22.4	47.8	52.3	65.0	61.0	55.1	68.1	20	M10 x 60 (40)	230 (16)
1"	26.2	52.3	58.7	70.1	67.1	62.0	72.9	20	M10 x 65 (40)	230 (16)
1-1/4"	30.2	58.7	73.2	79.0	79.0	75.9	82.0	20	M10 x 65 (40)	230 (16)
1-1/2"	35.8	69.9	82.6	93.0	90.9	85.1	96.0	20	M12 x 70 (45)	230 (16)
2"	42.9	77.7	96.8	102.1	102.1	100.1	104.9	20	M12 x 75 (50)	230 (16)
2-1/2"	50.8	88.9	108.7	114.0	114.0	111.0	117.1	20	M12 x 80 (55)	230 (16)
3"	62.0	106.4	131.1	134.1	135.9	133.1	136.9	25	M16 x 80 (60)	230 (16)
4"	77.7	130.3	152.4	162.1	160.0	154.9	165.1	30	M16 x 90 (70)	230 (16)
5"	92.1	152.4	180.0	184.0	185.0	183.0	186.0	40	M16 x 110 (70)	230 (16)
6"	208.0	-	236.0	-	249.0	249.0	249.0	40	M16 x 110 (70)	230 (16)
8"	275.0	-	317.0	-	330.0	330.0	330.0	40	M20 x 120 (75)	230 (16)

*** SHCS Bolt Specification**

Carbon Steel: DIN 912/ISO 4762, Minimum Grade 8.8
 316 Stainless Steel: A4-70, DIN 912/ISO 4762

3D step models available upon request

Introduction

Technical Data

Pipe Selection Guide

16 bar, 90° Flare

ANSI 150#, 300# Flare

SAE 1000, 70 bar

SAE 3000, 210 bar

SAE 6000, 420 bar

SAE 10000, 690 bar

ISO 6164, 400 bar

ISO 6164, 400 bar F10° Flare

Clamp Supports - Heavy Series

Valves, Ball and Check

16 bar 90° Flare Flange with Clearance Holes, Metric Tube Only

Flange pattern according to SAE J518 Code 61 (ISO 6162-1)



1-1/2" – 5" Flanges

6 - 8 Flanges

FFCN14, FFCN34, FFC18 Flare Flange with Clearance Holes, Metric

Size	Tube O.D. x wall mm	Standard Part Number	Working Pressure PSI (bar)	Weight lbs (kg)	Ød Max (mm)	Gasket Part Number
1/2"	25 x 2.0	FFCN34-050-25MM-*	230 (16)	0.44 (0.20)	33.0	08NG
3/4"	30 x 2.0	FFCN34-075-30MM-*	230 (16)	0.44 (0.20)	41.5	12NG
1"	38 x 2.5	FFCN34-100-38MM-*	230 (16)	0.44 (0.20)	47.3	16NG
1-1/4"	42 x 3.0	FFCN34-125-42MM-*	230 (16)	0.88 (0.40)	54.0	20NG
1 1/2"	50 x 3.0	FFCN14-150-50MM-*	230 (16)	1.10 (0.50)	65.3	24NG
2"	60 x 3.0	FFCN14-200-60MM-*	230 (16)	1.54 (0.70)	76.0	32NG
2-1/2"	73 x 3.0	FFCN14-250-73MM-*	230 (16)	1.76 (0.80)	90.0	40NG
3"	90 x 3.0	FFCN14-300-90MM-*	230 (16)	3.08 (1.40)	106.0	48NG
4"	115 x 4.0	FFCN14-400-115MM-*	230 (16)	4.40 (2.00)	135.0	64NG
5"	140 x 3.5	FFCN14-500-140MM-*	230 (16)	7.04 (3.20)	161.5	80NG
6"	165 x 3.5	FFCN18-600-165MM-*	230 (16)	13.64 (6.20)	191.5	96NG
8"	220 x 4.0	FFCN18-800-220MM-*	230 (16)	24.20 (11.00)	254.0	128NG

*** Materials:**

Standard, No Designation = Carbon Steel, Zinc Nickel Plated.

HDG = Carbon Steel, Hot Dip Galvanized.

SS = Stainless Steel, Type 316.

Ordering Example: FFCN14-150-50MM-SS

* Insert Material _____

Gasket Material:

KLINGERSIL C-4430 or equivalent, outstanding stress retention, resistance to hot water and steam as well as to oils, gases, salt solutions, fuels, alcohols, hydrocarbons, lubricants and refrigerants.

- Optimum combination of synthetic fibers bonded with NBR. Thickness 3.0mm
- DNV-GL Type Approved
- Fire-Safe according to ISO 19921
- Meets ASTM F104

